



PRODUCT SPECIFICATION

ASTM D3034 PVC GRAVITY SEWER PIPE

SDR35 or SDR26 Gasketed Joint

Hawk Plastic’s ASTM D3034 gasketed bell PVC pipe is manufactured to meet all the industry standards in addition to Hawk’s own rigorous quality control requirements.

Our D3034 gasketed pipe utilizes Rieber style gaskets throughout the entire product line to create a secure leak-free joint.

SPECIFICATIONS	
Pipe Standard:	ASTM D3034
Nominal Sizes:	4", 6", 8", 10", 12"
Dimension Ratios & Pipe Stiffness:	SDR35- 46 psi or SDR26- 115psi
Pressure Ratings:	Not rated for pressure applications
Lay Length:	14 Feet
Color:	Green or White
Pipe Compound:	ASTM D1784 Cell Class 12454 or 12364
Pipe Options:	Solid Wall, 2 Hole Perforated or 3 Hole Perforated
Pipe Joint Standard (gasketed) :	ASTM D3212
Max Angular Joint Deflection:	1°
Gasket Standard:	ASTM F477
Gasket Material Offered:	Standard- SBR or Optional- EPDM
Installation Standard:	ASTM D2321

Hawk Plastics 193 First Rd. Childersburg, AL 35044 Phone: 800-467-4295 Fax: 256-378-3079



PRODUCT SPECIFICATION

ASTM D3034 PVC GRAVITY SEWER PIPE

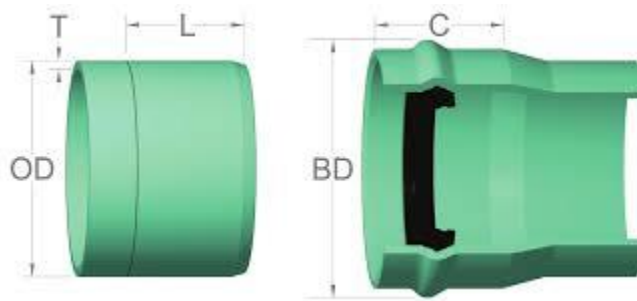

D3034 GASKETED PIPE DIMENSIONS								
Nom. Size	Outside Diameter (OD)	SDR	Pipe Stiffness (psi)	Min. Wall Thickness (T)	Internal Diameter	Approx. Bell Diameter (BD)	Bell Depth (C)	Insertion Mark (L)
4"	4.125	35	46	0.120	3.975	5.000	3.750	3.125
6"	6.275	35	46	0.180	5.915	7.375	4.625	4.000
8"	8.400	35	46	0.240	7.920	9.625	5.250	4.125
10"	10.500	35	46	0.300	9.900	12.250	5.875	5.125
12"	12.500	35	46	0.360	11.780	14.375	6.500	5.375
Nom. Size	Outside Diameter (OD)	SDR	Pipe Stiffness (psi)	Min. Wall Thickness (T)	Internal Diameter	Approx. Bell Diameter (BD)	Bell Depth (C)	Insertion Mark (L)
4"	4.125	26	115	0.162	3.891	5.000	3.750	3.125
6"	6.275	26	115	0.241	5.793	7.375	4.625	4.000
8"	8.400	26	115	0.323	7.754	9.625	5.250	4.125
10"	10.500	26	115	0.404	9.692	12.250	5.875	5.125
12"	12.500	26	115	0.481	11.538	14.375	6.500	5.375

NOTES:

All dimensions are in inches

These Dimensions are for estimating purposes only

SDR = Standard Dimension Ratio

Hawk Plastics 193 First Rd. Childersburg, AL 35044 Phone: 800-467-4295 Fax: 256-378-3079



PRODUCT SPECIFICATION

ASTM D3034 PVC GRAVITY SEWER PIPE

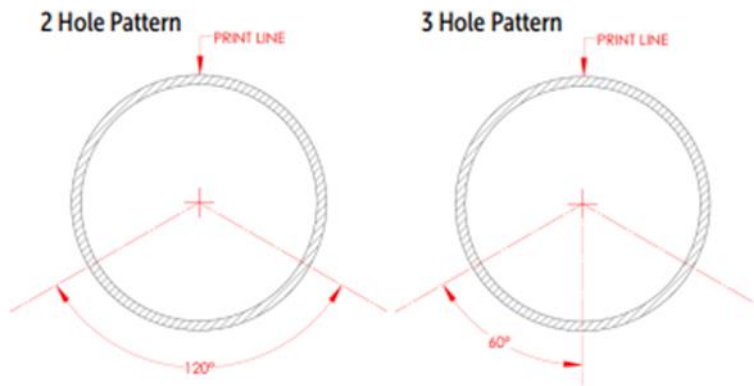

D3034 GASKETED PIPE PERFORATION PATTERNS					
Nom. Size	Perforation Rows	Circumferential Hole Spacing	Longitudinal Hole Spacing	Hole Diameter	Inlet Area (in ² /ft pipe)
4"	2	120°	5.000	0.500	0.942
4"	3	60°-60°	5.000	0.500	1.414
6"	2	120°	5.000	0.500	0.942
6"	3	60°-60°	5.000	0.500	1.414
8"	2	120°	5.000	0.500	0.942
8"	3	60°-60°	5.000	0.500	1.414

NOTE: AASHTO M-278 Perforation pattern is also available

Hawk Plastics 193 First Rd. Childersburg, AL 35044 Phone: 800-467-4295 Fax: 256-378-3079